

PANTHER T14R



PAYLOAD
29,100 lb • 13,200 kg



SPEED
8.4 mph • 13.5 km/h



CAPACITY
8.5 yd³ • 6.5 m³



ENGINE

Make/Model/Type	Caterpillar C7.1 Diesel engine	
Emission Level	EPA Tier 4 Final / EU Stage V	
Max Power Output	275 HP @2200 rpm	205 kW @2200 rpm

TRANSMISSION

Hydrostatic variable displacement pumps and motors

UNDERCARRIAGE

Track Type	Metal-embedded rubber track (MERT)	
Track Width	29.5 in	750 mm
Ground Clearance	20 in	509 mm
Ground Pressure		
without load	3.90 psi	26.9 kPa
with load	7.04 psi	48.5 kPa

BRAKE

Service Brake	Wet Multiple Disk Brakes
---------------	--------------------------

PERFORMANCE

Payload	29,100 lb	13,200 kg
Travel Speed	8.4 mph	13.5 km/h
Dump Body Capacity		
Struck	6.6 yd ³	5.1 m ³
Heaped	8.5 yd ³	6.5 m ³
Operating Weight	36,663 lb	16,630 kg
Maximum Gradeability		
Uphill/Downhill	33%	15°
Side hill	33%	15°

FLUID CAPACITIES

Diesel Fuel	74 gal (US)	280 l
DEF / AdBlue [®]	7.1 gal (US)	27 l

ELECTRICAL SYSTEM

Voltage	12 V
Alternator Capacity	150 A
Battery Capacity	1150 CCA (two)

Pinoth[®]

EQUIPMENT

STANDARD EQUIPMENT

Operator environment

Spacious wide cab – 1 person
Tilt and telescopic steering wheel
Foot throttle pedal
Operator seat with suspension and adjustments
Air conditioning
Adjustable temperature, fan control and fresh air intake
Three-point seat belt
Front and rear wipers with adjustable speeds
Windshield washer
Two exterior mirrors (right-side remotely adjustable)
Main display 4.3 in (111 mm)

Safety

Rear and side-view cameras
Inclinometer built-in display's with adjustable alarms
Parking brake linked to seat belt and armrest
Side window emergency exit
ROPS ISO 3471
Back-up alarm
Horn
First aid kit
Fire extinguisher

Electrical and Lighting

Working lights, LED (two front, one rear)
Batteries maintenance-free (two)
Battery disconnect switch

Other

Pressurized hydrostatic oil tank
Lockable compartments for fluids and batteries
D-ring for transportation (two)
Lockable door
Spare parts catalog
Operating and maintenance manuals

OPTIONAL EQUIPMENT

Bluetooth Radio, USB and AM/FM	FOPS ISO 3449	Front brushguard
Flashing LED beacon light	Engine block and hydraulic oil heaters	Counterweight
Trainer seat	Engine coolant heater	Emergency driving system

DIMENSIONS

A	117.3 in	2,980 mm	L	77.2 in	1,962 mm
B	101.2 in	2,570 mm	M	92.3 in	2,345 mm
C	71.7 in	1,820 mm	N	102.7 in	2,608 mm
D	20 in	509 mm	O	207 in	5,257 mm
E	29.5 in	750 mm	P	95.2 in	2,417 mm
F	233.7 in	5,936 mm	Q	127.2 in	3,232 mm
G	214.8 in	5,457 mm	r1	126.6 in	3,216 mm
H	181.3 in	4,604 mm	r2	126.3 in	3,207 mm
I	57.6 in	1,463 mm	a1	23°	
J	128.2 in	3,257 mm	a2	33°	
K	47.4 in	1,205 mm	a3	60°	

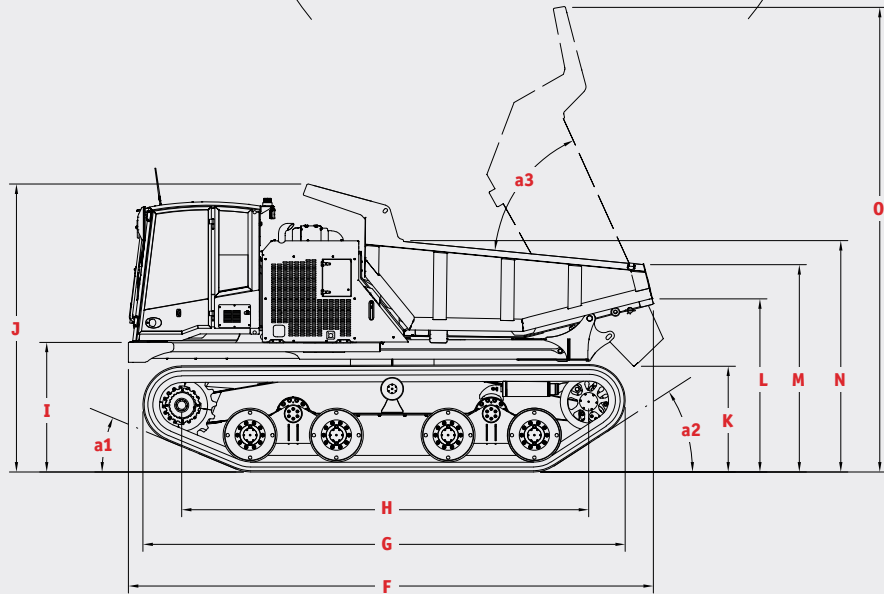
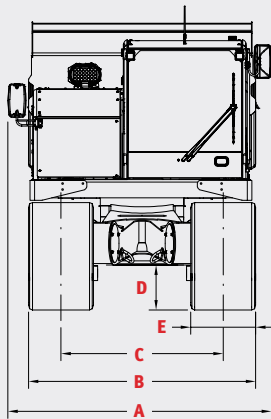
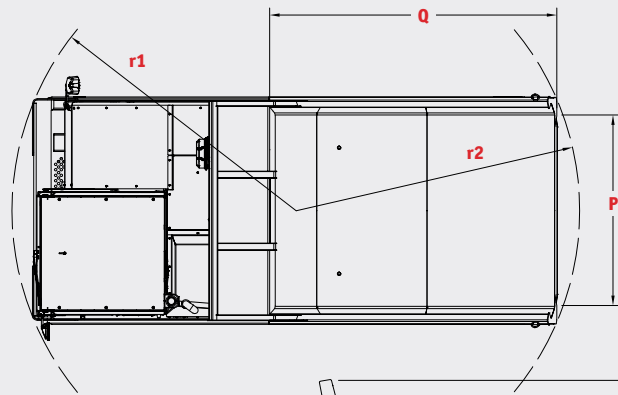

PRINOTH Ltd., 1001 J.-A. Bombardier Street, Granby QC J2J 1E9, CANADA

Service: 450-776-3663 after.sales.service.na@prinoth.com

Parts: 1-866-776-3636 parts.na@prinoth.com

Sales: 450-776 3600 sales.na@prinoth.com